

OEG-83J

Industrial X-Ray Tube



PRODUCT DESCRIPTION

The shockproof tube unit is designed specifically for quantitative analysis by fluorescence spectrometry. In X-ray fluorescence spectrometry, this unit provides intense, broad spectrum X-ray beams at short sample-to-target distances.

Maximum X-ray intensity is achieved by use of a thin beryllium window which is the only element of inherent filtration.

The cathode operates at ground potential eliminating window heating caused by electron bombardment usually inherent in anode grounded designs.

Water cooling of the X-ray target ensures the insert's capability of continuous operation up to 4,000 watts. A cathode jacket water cooling system removes filament heating energy.

CONSTRUCTION

The construction remains essentially the same as the well proven OEG-75. The cathode cooling coil has been relocated farther away from the window end, and the window frame has been redesigned to allow closer coupling to the sample being irradiated. The thin beryllium X-ray beam exit window is .003" (.076mm), and the target is 0.42" (10.7mm) from the end of the tube.

The shockproof housing is constructed of steel, is filled under vacuum with a specially processed insulating oil, and is hermetically sealed. An internal expansion chamber is provided to allow for a wide range of temperatures. The X-ray beam is projected along the longitudinal axis of the tube unit through the X-ray window which is located at the end of the tube. This construction increases accessibility to vacuum chambers and other accessories which must be placed close to the X-ray port.

The tungsten filament which is the cathode has the shape of a toroid surrounding the anode. This design permits placement of the target in a plane perpendicular to the central axis of the X-ray beam which reduces target-to-sample distance to a minimum.

Product Description

Insert Characteristics

Envelope: Grounded copper section external to housing, enclosing anode and cathode assemblies incorporates a beryllium X-ray window and includes filament feed-thru insulators and cooling coil for removing filament heat. Glass-to-metal section to insulate and support the anode enclosed in insulating housing.

Anode: Copper with target imbedded. Contains water cooling passage. Operates at positive high voltage with respect to grounded cathode jacket.

Target Material:

Rhodium (Rh), Copper (Cu), Molybdenum (Mo), Tungsten (W), Chromium (Cr), Platinum (Pt)

Target Angle: 90° to central x-ray beam and tube axis - Target surface is parallel to beryllium window.

Focal Spot: Toroidal, approximately 15mm OD x 5mm ID

Filament (Cathode): Toroidal, tungsten filament. Filament leads are insulated from the grounded support and focusing structure, but maintained near ground potential.

Filament (Cathode) Characteristics:

Operating Voltage Range: 6.0 - 13.0 volts AC or DC
 Operating Current Range: 7.0 - 11.5 amperes
 Filament Current (maximum): 11.5 amperes
 Filament Current for Full Load: 9.5 amperes for 53 mA, 75 kV constant potential (see Maximum Allowable Input Power Curves)

Filament Insulation from Ground: .1000 megohm minimum, 500V minimum breakdown. (see Operation Precautions)

Housing Characteristics

Electrical Rating:

Maximum Voltage: 75 kV Constant potential only. The high-voltage circuit should contain at least 20,000 ohms of added resistance. Maximum cable length is 30 feet.

Load Current (maximum) at 75 kV (constant potential)	53.3 mA	42.7 mA
Target Material	Rhodium, Platinum Molybdenum, Tungsten	Copper, Chromium

(see Maximum Allowable Input Power Curves)

Radiation Characteristics:

Inherent Filtration - Model J, 0.003" (0.076mm) Beryllium

X-Ray Coverage: Full-umbra coverage of 1.0" (25.4mm) diameter with specimen at 1.0" (25.4mm) from beryllium window.

Cooling Method:

Anode - Forced flow of demineralized, deoxygenated, and high resistivity water.

Cathode Jacket - Circulated anode water or forced flow of tap water.

Cooling Water Characteristics	Anode		Cathode Jacket	
Water resistivity: (minimum)	500,000 ohms-cm**		N/A	
Flow & Pressure drop:	3.5 qts/min (3.3 L/min)	33 psig (227.37 kPa)	0.7 qts/min** (.7 L/min)	1 psig (7 kPa)
			2.5 qts/min (2.4 L/min)	5 psig (35 kPa)
			3.3 qts/min (3.1 L/min)	10 psig (69 kPa)
Pressure (max) (above atmospheric)	60 psig (414 kPa)		60 psig (414 kPa)	
Temperature of water leaving tube: (maximum)	150°F (65°C)		150°F (65°C)	
Temperature of water entering tube	Do not operate at a temperature lower than ambient that condensation will not form on beryllium window or cathode body.****			

*Minimum flow rate

**Maintain this minimum flow whenever filament is energized. Water flow may be adjusted to higher values to control temperature of window end of X-ray tube.

***Maintaining resistivity of greater than one megohm-cm will result in improved tube life under continuous operation.

****Operating at lower than ambient temperature voids the Varex Imaging's warranty.

Terminal Connections:

Anode - Shockproof high-voltage cable receptacle conforms to Nema XR7-1979

Filament - Filament cable 20 foot. 2 conductor No.14 AWG

Ground/Earth: Terminal Available.

UL/CSA: UL classified.

Finish: Nickel

Weight: Approximately 17 lbs. (7.7 kg)

 **WARNING**

Beryllium windows transmit a very high level of long wavelength X-radiation, which can injure human tissue.

Injury may occur from even very short exposures to the primary X-ray beam.

Follow all precautions necessary to avoid radiation exposure to humans.

The radiation dose rate cannot be accurately measured with conventional radiation measurement instruments. Radiation intensity in each installation will vary, and calibration must include the effects of long wavelength X-radiation.

Fumes from beryllium metal (or its compounds) as well as dust can be hazardous if inhaled. During use, corrosion products may occur on the beryllium window, but these should not be scraped off, machined, or otherwise removed. Tube unit disposal should conform to federal, state, and local regulations governing beryllium.

Product Description

INITIAL INSPECTION

When an OEG-83J is received, it should be unpacked and inspected as soon as possible. Care should be taken to keep from jarring the tube or the inner packing box, since the internal glass envelope may become damaged. Grasp the tube firmly with both hands and tilt or shake the tube. A rattle or gurgle from within indicates a broken insert.

Care must be used when handling the tube not to touch or apply any pressure to the exposed beryllium window. A careful inspection should be made for any visible damage, such as a broken beryllium window which may have occurred in transit.

Carefully examine the beryllium window for signs of corrosion which will appear in the form of white beryllium oxide spots. The use of a 5x or 10x eye loupe will usually reveal any corrosion products. A corroded window will usually be followed by loss of vacuum through perforation of the window.

The tube serial number is stamped 180° opposite to where the filament terminals emerge from the vacuum tube part of the assembly and must agree with the name plate number.

An ohm meter or Megger®-type device may be used to determine if a filament (cathode)-to-insert body short has occurred. A filament body short will prevent reading tube current when the tube current metering is in the filament (cathode) circuit.

®Megger is a registered trademark of the J.D. Biddle Co.

EQUIPMENT DESIGN CONSIDERATIONS

(Mechanical Installation)

The window end of the tube unit is provided with a flanged, finished surface for use with an "O"-ring gasket when the tube is to be attached to a vacuum chamber.

The tube unit may be mounted and operated with the window up, down, or at any angle. In the window up position, precautions must be taken to assure full water flow to the anode cooling circuit for a minimum of 5 seconds after anode power is cut off. Anode cooling water should be at full flow before turning on anode power in all positions.

A low resistance electrical connection should be made between the housing and ground.

COOLING

Precautions should be taken to inhibit the entrance of atmospheric oxygen or other gases such as SO₂, CO, CO₂ into the anode cooling water which will greatly foreshorten the life of the tube unit. Damage may occur in two ways: 1) producing oxides or compounds that reduce cooling or 2) corrosive thinning of anode wall and eventual loss of tube vacuum. Oxides which build up on the cooling surface of the anode cooling passage interfere with heat transfer, resulting in evaporation or melting of the target. This may also produce gas, which would eventually result in electrical breakdown of the tube, or the evaporated target material may deposit on the beryllium window which would decrease radiation output. In either case, the cooling water may wash away the oxide or compound as it forms, resulting in a gradual thinning of the anode wall and eventually in perforation of the anode wall and loss of tube vacuum.

The compounds can also deposit on the inside wall of the insulating cooling ducts within the housing carrying the cooling water to the anode and form a conductive coating that will add a parallel current flow to the anode current. This additional current will, by electrolytic action, erode away the metal surfaces at the anode which in time will cause water leakage into the housing insulating oil causing high voltage arc-over and premature destruction of the vacuum tube.

To assure proper purity of the cooling water, the following precautions should be taken:

- A demineralizing cartridge and an oxygen removal cartridge (refer to ORDERING INFORMATION note) must be used in series with the water cooler and tube unit, and must be changed when the anode cooling water resistivity falls below the specified limit.

This precaution is necessary since even demineralized, low-conductivity cooling water may contain dissolved and entrained oxygen which will cause severe corrosion.

- seal the reservoir to minimize entrance of atmospheric oxygen or other harmful gases into the anode cooling water.
- introduce nitrogen into all spaces in the water cooler where the water surface would otherwise be exposed to air.

Anode cooling efficiency will be impaired if stray particles in the purified water supply are greater than .020" diameter.

WARRANTY NOTE

OEG-83 series tube units which fail prematurely will not be covered by the Varex Imaging's warranty when inspection at our factory indicates that a failure occurred due to excessive oxidation of anode water cooling passages.

Note: Cartridges for a water demineralizer and a deoxygenator are required for operation of the anode cooling system of the OEG-83. These are not available from Varex Imaging but should be ordered directly from Barnstead Co., P.O. Box 797, 2555 Kerper Blvd., Dept. TR, Dubuque IA 52004-0797, Telephone 319-556-2241. Refer to Barnstead Part No. 09-034-8(D0811). Barnstead Co. can also supply the complete water circulating system, if desired.

Product Instructions

OPERATION PRECAUTIONS

Since the cathode jacket of the tube is operated at ground potential, ordinary tap water can be used for cooling this part of the tube unit. However, the water should be reasonably free from corrosive or scale-producing impurities. Whenever the filament is energized, the specified minimum water flow rate should be maintained to prevent reaching excessive housing temperature due to filament heat. The cathode jacket may be connected in series with the anode cooling circuit, allowing the use of a single circulating pump without substantially incurring back pressure in the supply circuit.

The tube current metering circuit should be arranged so as not to read that portion or anode current due to leakage through the anode cooling water. The filament leads or the tube unit are insulated from ground to facilitate the measurement of tube current.

The preferred tube current metering circuit is to place the meter in series with the filament (cathode) transformer winding center tap and tube unit ground.

The filament must not be more than 5 volts dc, positive or negative, with respect to ground since biasing will distort the focal spot size and distribution. Operation with bias will nullify the warranty on this tube unit.

Under self bias conditions which can occur if the filament power transformer winding accidentally disconnects from ground (such as an open meter), the focal spot can shrink in size to a small diameter circular line which if under full power loading will melt the target material in a few seconds and ruin the tube unit.

Note

A protective device such as a zener diode should be employed between the filament circuit and ground to prevent the filament supply conductors from reaching a high potential in the event of interruption of the tube current metering circuit to ground.

This tube may be operated only with constant potential and must be connected to the high-voltage supply through the specified protective resistance.

Do not exceed either the mA values indicated under "Load Current" or the maximum allowable filament current. Otherwise, tube life may be shortened appreciably.

Operation of the tube in high humidity conditions with the window temperature below ambient must be avoided. Condensation on the beryllium window will cause corrosion and subsequent window perforations. The thin window is very susceptible to this moisture perforation problem. Care should be taken to prevent water and other foreign materials from coming in contact with the beryllium surface.

CALIBRATION

Prior to the operation of the tube, both the high-voltage and filament energy sources should be calibrated. Kilovoltage calibration should be performed to ensure that the maximum voltage rating of the tube is not exceeded. Filament control circuit calibration is necessary to permit the filament current to be preset for any desired tube milli-ampere before each exposure.

STORAGE AND SHIPPING

Prior to storage or shipping, all water and water vapor must be removed from the cooling tubes and ducts. Failure to remove all water can result in loss of vacuum through corrosion and perforation of the thin beryllium window. To remove water:

- remove the plugs from the cooling connection fittings
- place the tube unit in a vertical position with the cooling connections down
- blow compressed air through each inlet fitting for a few minutes

Replace the plugs on the cooling connections before packing.

For additional protection of the beryllium window during storage or shipment an evacuable hermetic cap (Part # 560018) is supplied which seals to the tube unit through an "O" ring. A rough vacuum pump or other device capable of attaining a 5" (125mm torr) or better vacuum is required for use of this cap.

The original packing or its equivalent must be used when reshipping the tube unit. The tube unit should be wrapped in the plastic bag in which it was received and a bag of dry desiccant placed inside before sealing the bag. The desiccant originally used can be dried by baking in an oven at 212°F (100°C) for a few hours.

Minimum Temperature for Storage or Transportation: 15°F (-9.4°C)

AGING PROCEDURE

Full rated peak kilovoltage must not be applied immediately to these tubes after they have been idle for a period of time. Initial operation must begin at a reduced kVp, and the voltage must be gradually raised in small steps until the intended operating voltage is reached. A suggested schedule is given in the following table. If instability is observed at any step, the time for that step must be increased until the tube has operated for at least 5 minutes with no further instability. If instability is violent, return to the previous step. Instability can be observed as fluctuations on the mA meter.

If instability is observed at progressively lower kVp levels, or if instability persists at a low kVp level, operation should be discontinued. Operation should be discontinued in any event if "crackling" or "spitting" sounds occur within the housing, indicating arcing or corona through the oil insulation. Continued operation under such conditions may result in serious damage to an otherwise repairable tube.

Schedule for Aging

kV Range: 20 - 75 kV (or tube maximum operating voltage) constant potential

kV per Step: 5 kV

Idle Period*	Time per Step	Approx. Total Time
New tubes and more than 3 months	5 min.	50 min.
72 hours to 3 months	2 min.	20 min.
12 hours to 72 hours	1/2 min.	5 min.

* If the tube is operated continuously, for instance overnight, at 30 kV and 20 mA, there will be no need for an aging procedure the following morning

Tube Outline Drawing

Dimensional Data		
REF	INCHES	MILLIMETERS
A	3.125 ±.005	79.38 ±.13
B	2.813 ±.005	71.45 ±.13
C	2.682 ^{+.000} / _{-.003}	68.12 ^{+.00} / _{-.08}
D	2.45 ±.02	62.23 ±.51
E	-	-
F	1.33 ±.02	33.78 ±.51
G	.709 ±.003	18.0 ±.08
H	1.447 ±.010	36.75 ±.25
J	.878 ±.005	22.17 ±.13
K	.40 ±.02	10.16 ±.51
L	.06 ±.02	1.52 ±.51
M	.598 ±.005	15.19 ±.13

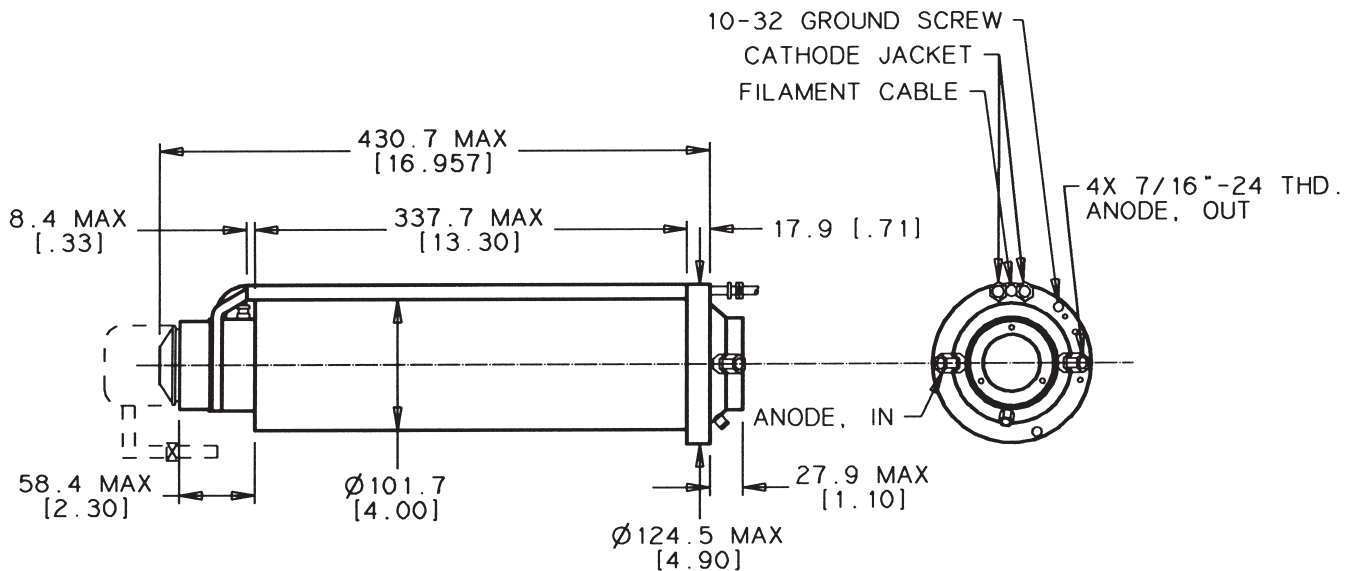
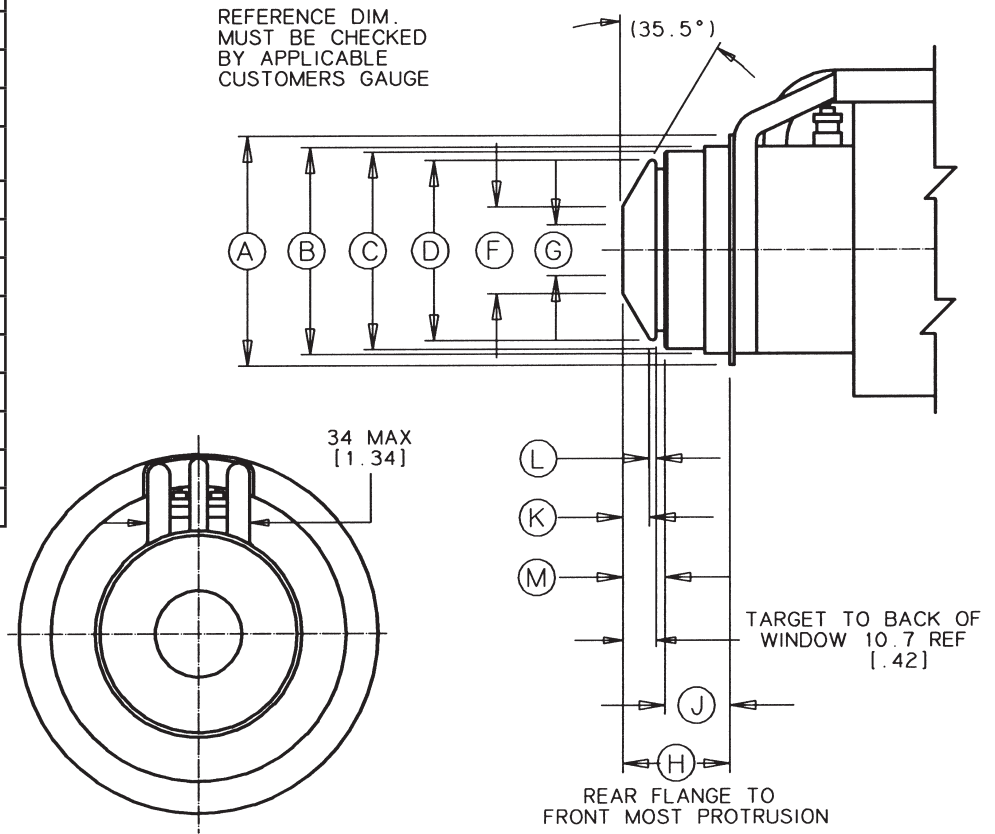

Filament Emission Charts

FILAMENT CHARACTERISTICS

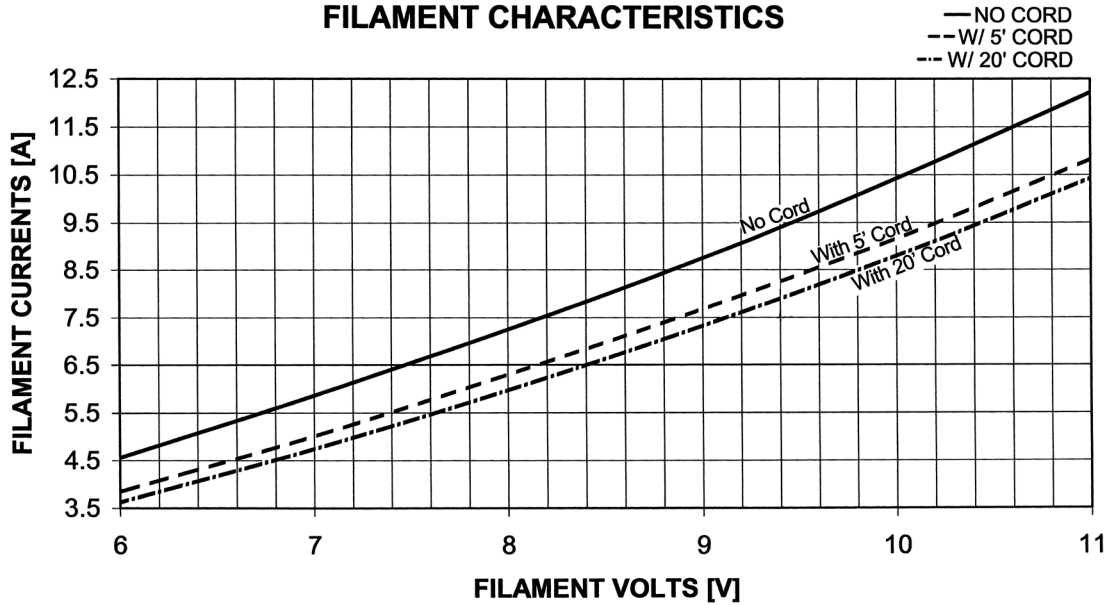

FILAMENT CORD: AWG #14, 2-CONDUCTOR
 Test leads: AWG # 18, 52" long

MAXIMUM ALLOWABLE INPUT POWER CURVES

