

IXS1015

100 kV, 150 W



Multipurpose Sources

Applications

Food Inspection Systems, Security Scanners, Industrial NDT, Product Quality Monitoring

Key Features

- Integrated High Voltage Generator, X-ray Tube, and Control Electronics
- High Stability
- Compact and Robust
- Radiation Shielded
- User Friendly RS232 Digital Interface

Specifications

Input Line Range	90–264 VAC, 50/60 Hz
Output kV	25–100 kV
Output mA	0.05–6.0 mA
Output Power	150 W continuous maximum
Voltage Regulation	Load: <0.1% at max kV output over the output mA range Line: <0.1% at max kV output over the input line range
Current Regulation	Load: <0.1% at max mA output over the output kV range Line: <0.1% at max mA output over the input line range
Ripple	kV: <0.5% p-p of maximum output mA: <0.5% p-p of maximum output
Repeatability	kV: <0.5% mA: <0.5%
Overshoot	kV: ≤ 5% of rated output
Output Rise Time	Standard Rise Time ≤500 ms from 10%–90% of max rated output
Cooling	Air Cooled (Water cooled option also available)
Radiation shield	Less than 0.5 mR/hr at 5 cm from the surface of the chassis as per FDA 21 CFR 1020.40
Safety and Regulatory Compliances	Designed to meet CE, EN/UL61010-1 and EN61326-1



Cone Beam X-ray Generator



Control Unit

Dimensions	Generator: 254mm x 143mm x 210mm Control unit: 254mm x 134mm x 65mm
Weight	Generator: 14 Kg Control unit: 2 Kg
X-ray Tube	Control Unit
X-ray Tube Type	Glass
X-ray Focal Spot Size	0.8 nominal as per IEC60336 0.5 available upon request
Beam Port	Fan beam: 80° X 10° max Cone beam: 30°
Operating Environment	
Operating Temperature	5°C to 40°C
Storage Temperature	-20°C to 85°C
Thermal Cut Off	60°C ± 3°C of oil temperature
Humidity	98% non-condensing



Generator

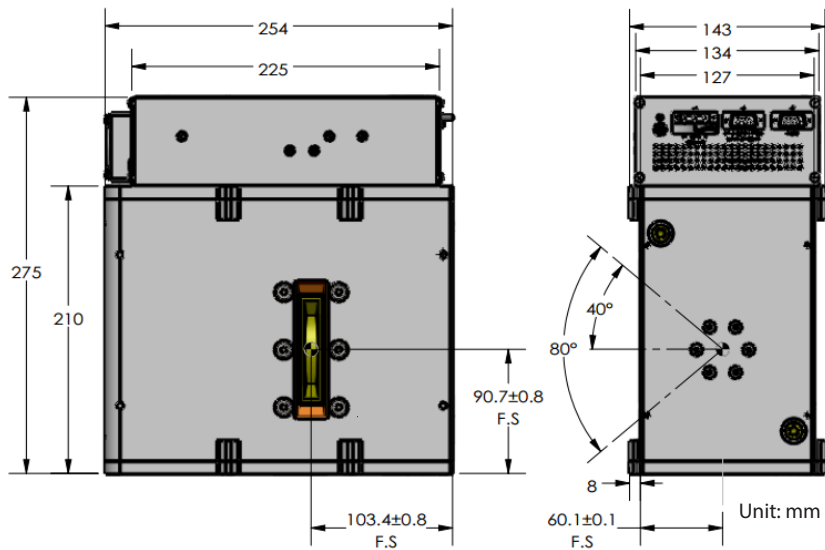

Control Unit

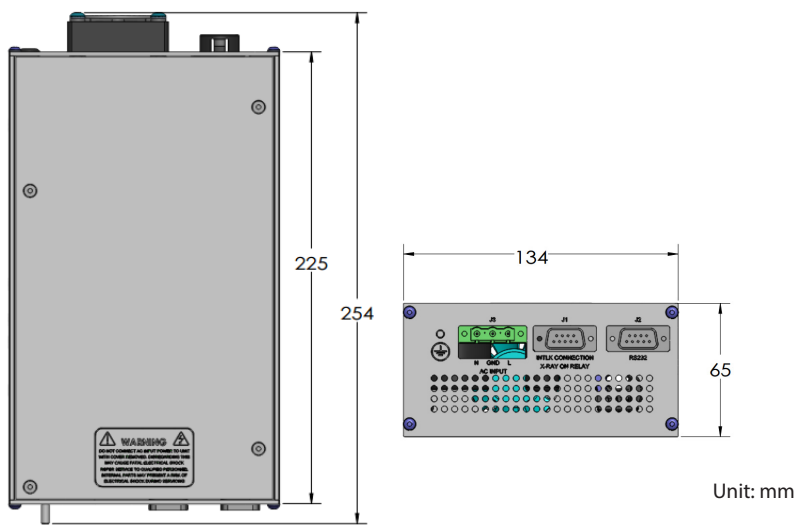

Graphical User Interface

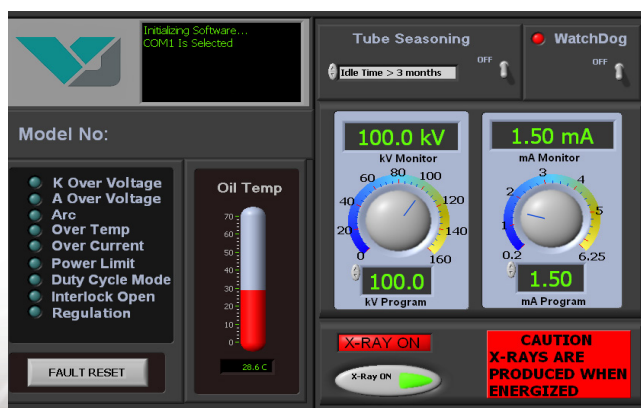

LED Indicators

X-RAY ON	Illuminated when interlock is closed and HV is enabled
POWER	Illuminated when power is present
OV	Over voltage fault
OP	Illuminated when selected power exceeds the rated power
OC	Over current fault
ARC	ARC-ing fault
OT	Illuminated when oil temperature exceeds 60°C ± 3°C

J1: Interlock Connection/ X-ray On Relay

Pin Out	Name
1	Interlock out
2	Interlock in
3	X-ray On Relay contact common
4	X-ray On Relay contact N/C
5	X-ray On Relay contact N/O
6	N/A
7	N/A
8	N/A
9	N/A

J2: RS232 Interface

Pin Out	Name
1	N/A
2	TX-(Transmit)
3	RX+(Received)
4	N/A
5	Signal Ground
6	N/A
7	N/A
8	N/A
9	N/A

J3: AC Input

N	Neutral
GND	Ground
L	90-264 VAC Input